



REPLY TO
ATTENTION OF

DEPARTMENT OF THE ARMY
THE INSTITUTE OF HERALDRY
9325 GUNSTON ROAD, ROOM S112
FORT BELVOIR, VIRGINIA 22060-5579

AAHS-IHS (840-10a)

NOV 03 2014

MEMORANDUM FOR Commander, HHC, 173d BSTB, ATTN: SSG Lawrence, C/O
CSM Reed, Unit 31430, Box 5, APO AE 09605-1430

SUBJECT: Beret Flash and Background Trimming for the 54th Engineer Battalion

1. The request for a beret flash and background trimming for the 54th Engineer Battalion is approved. Forwarded for your organizational records is the authorization letter (encl 1).
2. Also enclosed for use in procurement of the items are:
 - a. Manufacturing drawings for the flash and trimming (TIOH Dwg. No. A-4-296 and A-6-324) (encls 2 and 3).
 - b. Color prints and black and white line drawings of the flash and trimming (encls 4 and 5).
 - c. A list of certified manufacturers and procedures for local procurement of insignia (encls 6 and 7).
3. POC this Institute is Mrs. Henning by telephone at DSN 656-4972, Commercial (703) 806-4972 or by email at Bonnie.Henning@us.army.mil.

7 Encls
as

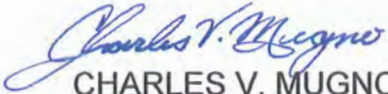
CHARLES V. MUGNO
Director



REPLY TO
ATTENTION OF

DEPARTMENT OF THE ARMY
THE INSTITUTE OF HERALDRY
9325 GUNSTON ROAD, ROOM S112
FORT BELVOIR, VIRGINIA 22060-5579

AAHS-IHS (840-10a)

NOV 03 2014

MEMORANDUM FOR Commander, HHC, 173d BSTB, ATTN: SSG Lawrence, C/O
CSM Reed, Unit 31430, Box 5, APO AE 09605-1430

SUBJECT: Beret Flash and Background Trimming for the 54th Engineer Battalion

1. In accordance with the provisions of AR-670-1, a beret flash and background trimming are authorized for wear by members of the 54th Engineer Battalion.
2. The descriptions of the designs are as follows:

BERET FLASH

A silver gray shield-shaped embroidered item with a semi-circular base surmounted by a red shield-shaped; all within a 1/8 inch (.32 cm) white border. The overall dimensions are 2 1/4 inches (5.72 cm) in height and 1 7/8 inches (4.76 cm) in width

BACKGROUND TRIMMING

A silver gray oval-shaped embroidered item surmounted by a red shield-shaped device; all within a 1/8 inch (.32 cm) white border. The overall dimensions are 1 3/8 inches (3.49 cm) in height and 2 1/4 inches (5.72 cm) in width.

CABLE NUMBERS OF COLORS

| | |
|-------------|--------|
| Silver Gray | #67137 |
| White | #67101 |
| Scarlet | #67111 |

3. This authorization does not grant exclusive use of the above colors and pattern design for the 54th Engineer Battalion.

Charles V. Mugno
 CHARLES V. MUGNO
 Director

CF: CMH

REVISIONS

| LTR | DESCRIPTION | DATE | APPROVED |
|-----|-------------|------|----------|
|-----|-------------|------|----------|

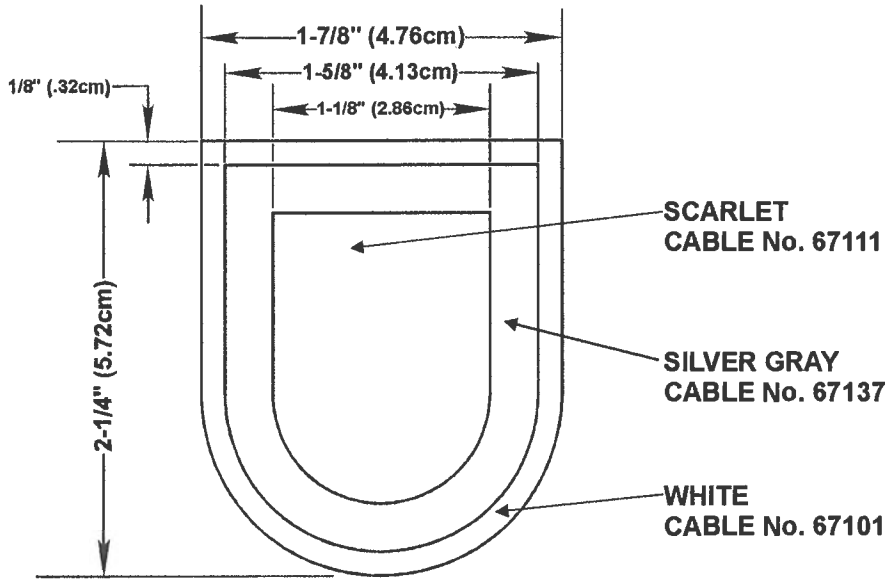

DESIGNED FOR OVEREDGE STITCHING

UNLESS OTHERWISE SPECIFIED DIMENSIONS ARE IN INCHES
TOLERANCES ON FRACTIONS DECIMALS ANGLES

MATERIALS:
TO BE MANUFACTURED IN ACCORDANCE WITH MIL-DTL-14652

| | | |
|----------|---|------------|
| EXAMINED | <i>TLC</i> | |
| CHECKED | <i>CA</i> | <i>SAO</i> |
| PREPARED | <i>CA</i> | |
| APPROVED |  CHARLES V. MUGNO DIRECTOR | |

THE INSTITUTE OF HERALDRY, DEPARTMENT OF THE ARMY
9325 GUNSTON RD, RM S-113 FORT BELVOIR, VA 22060-5579

**BERET FLASH FOR
FIFTY-FOURTH ENGINEER
BATTALION**

| | | |
|----------|-------------------|------------------------|
| SIZE | CONTROL IDENT. NO | A-4-296 |
| A | 22571 | |
| SCALE | FULL | DATE |
| | | 29 OCTOBER 2014 |

REVISIONS

| LTR | DESCRIPTION | DATE | APPROVED |
|-----|-------------|------|----------|
|-----|-------------|------|----------|

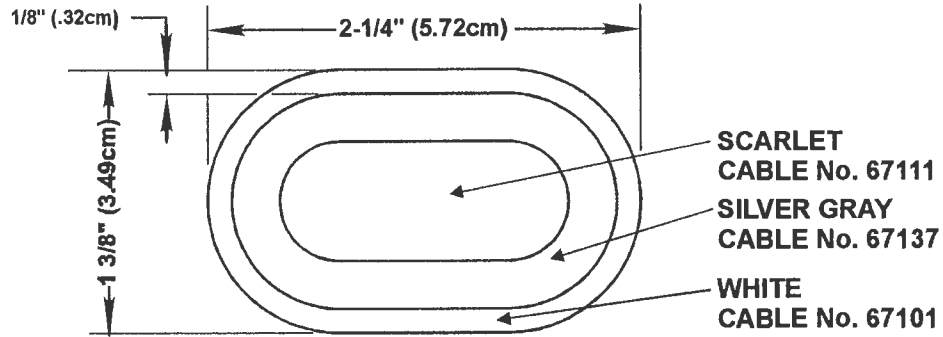

DESIGNED FOR OVEREDGE STITCHING

UNLESS OTHERWISE SPECIFIED DIMENSIONS ARE IN INCHES
TOLERANCES ON FRACTIONS DECIMALS ANGLES

MATERIALS:
TO BE MANUFACTURED IN ACCORDANCE WITH MIL-DTL-14652

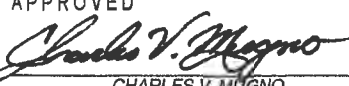
| | |
|----------|---|
| EXAMINED | |
| CHECKED | |
| PREPARED | A |
| APPROVED |  CHARLES V. MUGNO DIRECTOR |

THE INSTITUTE OF HERALDRY, DEPARTMENT OF THE ARMY
9325 GUNSTON RD, RM S-113 FORT BELVOIR, VA 22060-5579

BACKGROUND TRIMMING FOR
FIFTY-FOURTH ENGINEER
BATTALION

| | | |
|------------------|-----------------------------------|--------------------------------|
| SIZE A | CONTROL IDENT. NO 22571 | A-6-324 |
| SCALE | FULL | DATE 29 OCTOBER 2014 |

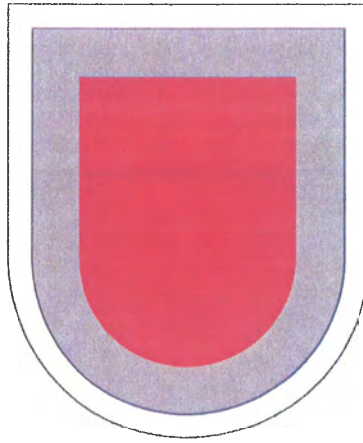

FLASH

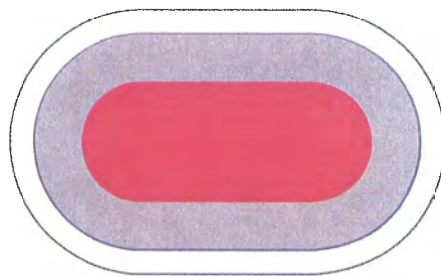

TRIM

**FLASH and TRIM
54TH ENGINEER BATTALION**

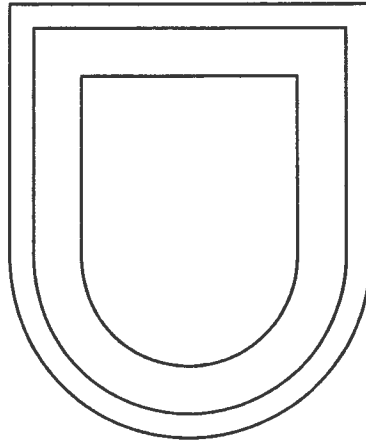

FLASH

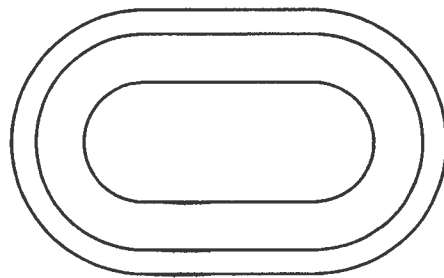

TRIM

FLASH and TRIM
54TH ENGINEER BATTALION